

AMX 0.2CN

Wall Mount CobraNet® Interfaces



MEDIA
TECHNOLOGY
SYSTEMS



The AMX0.2CN is a 2-gang wall mount CobraNet® interface with 2 analog line level outputs, 16 CobraNet® input streams and 8 CobraNet® output streams. The internal DSP processing provides a 12 channel AutoMixer with signal processing for EQ, High Pass, Low Pass, Compressor and Delay, including remote triggering of camera positioning presets. In addition, 5 AMX0.2CN's can be combined to make a 56x10 matrix.

KEY BENEFITS

- **LAN technology:** The AMX0.2CN is 2-gang wall mount Decora® faceplate that converts Ethernet audio streams into analog audio (CobraNet® protocol). The AMX0.2CN is designed to work with any brand of Cobanet input interface.
- **On-board DSP with Automatic Microphone Mixer:** The AMX0.2CN provides an Automatic Microphone Mixer matrix of optional size-12x2, 20x4, 32x6, 44x8, or 56x10 across 1-2-3-4-5 linked devices, respectively. In addition, the AMX0.2CN has HP/LP filters, 8 band Parametric EQ and 'look ahead' Compressors on each output channel.
- **Aesthetics:** Fits standard backboxes and decorative faceplates in different finishes to suit the needs of the creative consultants
- **Value added:** The AMX0.2CN leverages additional value from the investment into the structured cable system, as the MTS AMX0.2CN interface is simply an additional LAN 'endpoint' on the building network.
- **Low cost LAN cable/Many channels:** One UTP cable carries multiple audio channels (instead of one costly microphone cable for one audio channel)
- **Low Cost LAN Connector/Reduced cost of labor:** Replaces the skilled labor and long hours required to solder terminate, impedance check and polarity check speciality XLR/RCA audio connectors with the widely available skillset required to crimp/terminate RJ45 connectors.
- **Rapid deployment:** Critical path delivery is dramatically reduced, as one technician can terminate and test an entire ballroom (say 48 ION UTP ports) in a morning compared to days for an analog solution with patch bays
- **Future proofed:** Once the audio system is part of the structured cabling solution, then upgrading to future audio network products is 'plug and play'.
- **Integration:** Simple integration with the Building Management System (BMS)
- **Eliminates noise problems:** Early conversion to digital eliminates the usual audio buzz & hum problems
- **Rapid Configuration:** The network addressing solution also allows complex patching and room combining to be achieved in seconds. For example, the configuration of a banquet room can be quickly changed from a daytime corporate function to an evening event.
- **Reliability:** Early conversion to Ethernet increases system reliability, as the system is not dependent on a single point of failure in the control room
- **Pro-Audio compliant:** Meets audio performance and signal interfacing needs for both consumer and professional audio applications.
- **PoE compliant:** No additional power supply is needed

APPLICATIONS

- Hotels/Hospitality
- Convention Centers
- Corporate Meeting rooms
- Classrooms and Lecture rooms

DETAILS

The AMX0.2CN is a CobraNet® LAN to Analog audio interface (in a convenient 2-gang wall mount package) with embedded DSP based signal processing. The interface is designed to fit commonly available decorative wall plates and backboxes from Leviton (Decora), MK, etc. This feature allows the installer to meet the Interior Designer or Architects requirements for color and finish.

The AMX0.2CN converts 2 channels of incoming CobraNet® data stream into analog audio signals. The XLR outputs have three different peak output sensitivities ...+22dBu (ProAudio), +18dBu (Prosumer) and +12dBu (Consumer and amplifiers). The RCA outputs are -8dBu nominal (+12dBu peak).

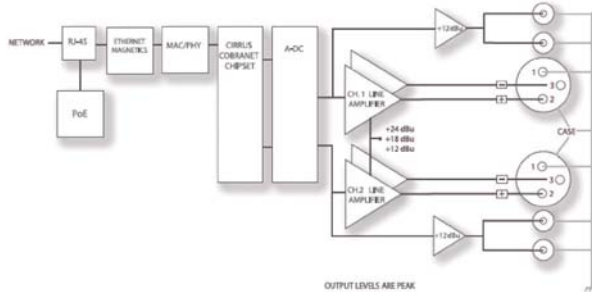

Note: The RCA's are summed to mono and combined with the XLR, so the AMX0.2CN is a 2 analog channel device, where each analog channel has one XLR and two RCA's.

Each AMX0.2CN provides the following input and output channels

- 16 CobraNet® Input Channels for audio feeds from MTS ION2.0, ION4.4, or any 3rd party CobraNet® devices.
- 8 CobraNet® output feeds for Device linking and Room Combining
- 2 Analog Output Channels to feed local powered loudspeakers or amplifiers.
- Up to 5 AMX0.2CN's can be linked to provide a 56x10 I/O matrix.

The AMX0.2CN can be wall mounted near the floor for portable pole mounted powered loudspeakers, mounted in the ceiling for powered ceiling loudspeakers, or near the ceiling for wall mounted powered loudspeakers.

The AMX0.2CN internal signal processing provides a 12 channel Automatic microphone Mixer with 4 expansion ports (the AMX0.2CN uses CobraNet® channels for the transfer of Automixer control and audio linker signals). The analog output channels each have HP, LP, 8 band Parametric EQ and a Compressor with a look ahead delay. There is also a single channel, 2 tap delay device (with up to 75mS on each tap) that can be switched into the output channels and/or used for cascading delays through multiple devices (see schematic below).

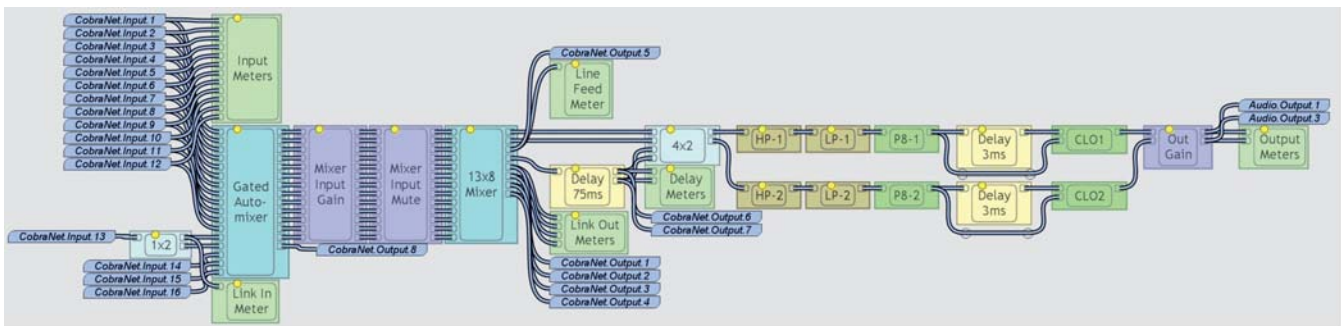

Up to five AMX0.2CN can be linked to provide an Automatic Microphone Mixer matrix size of 12x2, 20x4, 32x6, 44x8, or 56x8 across 1-2-3-4-5 linked devices, respectively.

The AutoMixer is a gated type with ambient threshold sensing, where the gate 'active' indicator can be used to trigger camera positioning presets.

The MTS ION2.0 provides the AMX0.2CN with wall mount CobraNet® inputs. The ION2.0 also handles all signal input processing (AGC, EQ, Filters, Compressor etc). However, the AMX0.2CN can work with any brand of CobraNet® compliant input interface.

An MTS ION4.4 (or ION8.8) provides the AMX0.2CN with control room/rack inputs and outputs, including line level sources and output feeds for amplifiers driving delayed arrays of ceiling loudspeakers. Individual AMX0.2CN's can provide up to 75mS delay for ceiling loudspeakers, ie cater to rooms of 30 meters long. In linked mode, the AMX0.2CN can cascade delays for 150mS, 225mS, 300mS, etc.

Linked AMX0.2CN's can also provide small system room combining solutions of 2, 3, 4 & 5 rooms with up to 10 microphones in each room.

The AMX0.2CN can connect with control room CobraNet® DSP in large venues. For example, AMX0.2CN's can provide the local meeting room solution, or combine with the central DSP for 'breakout' Events.

The AMX0.2CN offers SNMP control of all parameters via the CobraNet® LAN port. MTS provides a configurable system software package (MTS Control) that uses Stardraw Control as the core engine (see screenshot below).



A typical application for the AMX0.2CN is shown below...



The small meeting room system has two AMX0.2CN's either side of the head table, where the powered loudspeakers are plugged into the AMX0.2CN's. The head table microphones are plugged into ION2.0 wall mount interfaces, as are the boom arm microphones used for taking questions. The ION2.0's stream audio over the network to the AMX0.2CN and all control and configuration is done via a local or remote laptop or PC (see block diagram below).

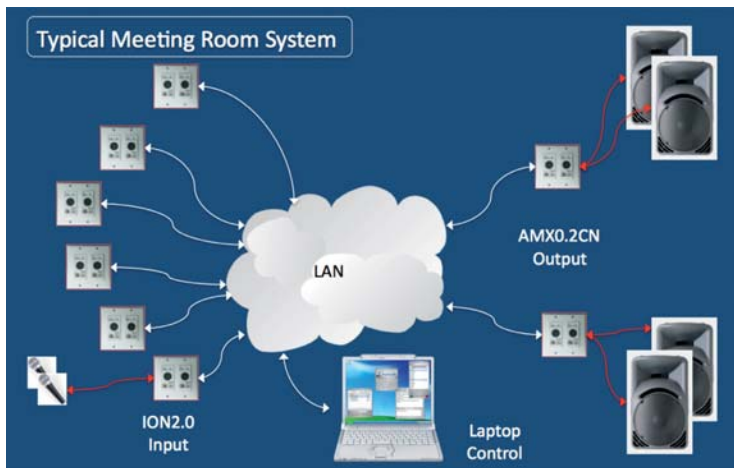

The two AMX0.2CN's will be linked and provide a 20x4 matrix mixer. Any line level signals (eg laptops, DVD players, etc) will pass through the Automixer in channel bypass.

SPECIFICATIONS

Frequency response:

20Hz-20kHz, +0/-1dB

THD:

<0.12%

EIN:

20Hz-20kHz, less than 121dBm

Hum and Noise:

>70dB below rated output

AMX0.2CN Analog outputs (note RCA's are mono and source from the XLR):

- Balanced XLR outputs: 200 ohm balanced, 100ohm unbalanced, 600ohm minimum load to preserve PoE stability. +22dBu peak
- XLR sensitivity switch: +22dbu, +18dBu, +12dbu (peak)
- Unbalanced RCA outputs: 10kohm impedance, -8dBu nominal, +12dBu peak

AMX0.2CN CobraNet® I/O:

- 16 channels of CobraNet® streaming input, selectable from any of 8 bundle receivers.
- Full channel submapping of both transmitters and receivers available.
- 4 channels of CobraNet® streaming output from the 8x8 matrix mixer for device interlinking. Up to 5 devices (4 remote plus local master) can be interlinked.
- 1 channel of CobraNet® streaming output from the 8x8 matrix mixer for a non-delayed mix to remote devices
- 2 channels of CobraNet® streaming output from the delay (pre local processing) for cascading remote ION0.2 devices for 105mS, 210mS, 315mS, etc delays to ceiling loudspeaker or cluster arrays.
- 1 channel of Automixer master control signal to slave AMX0.2CN devices.

Power Supply:

PoE

Control and Monitoring:

SNMP

Control Software:

MTS-CONTROL, CN Discovery (CNDISCO)

Size:

Fits standard 2-gang back box and Decora Faceplate. Rear PCB assy is 80mm (w) x 50mm (h) x 40mm (d).

Weight:

0.2kg (155x135x65mm & 0.33kg Packed).

CobraNet® is a trade mark of Cirrus Logic